

TICKET™

u s e r ' s m a n u a l

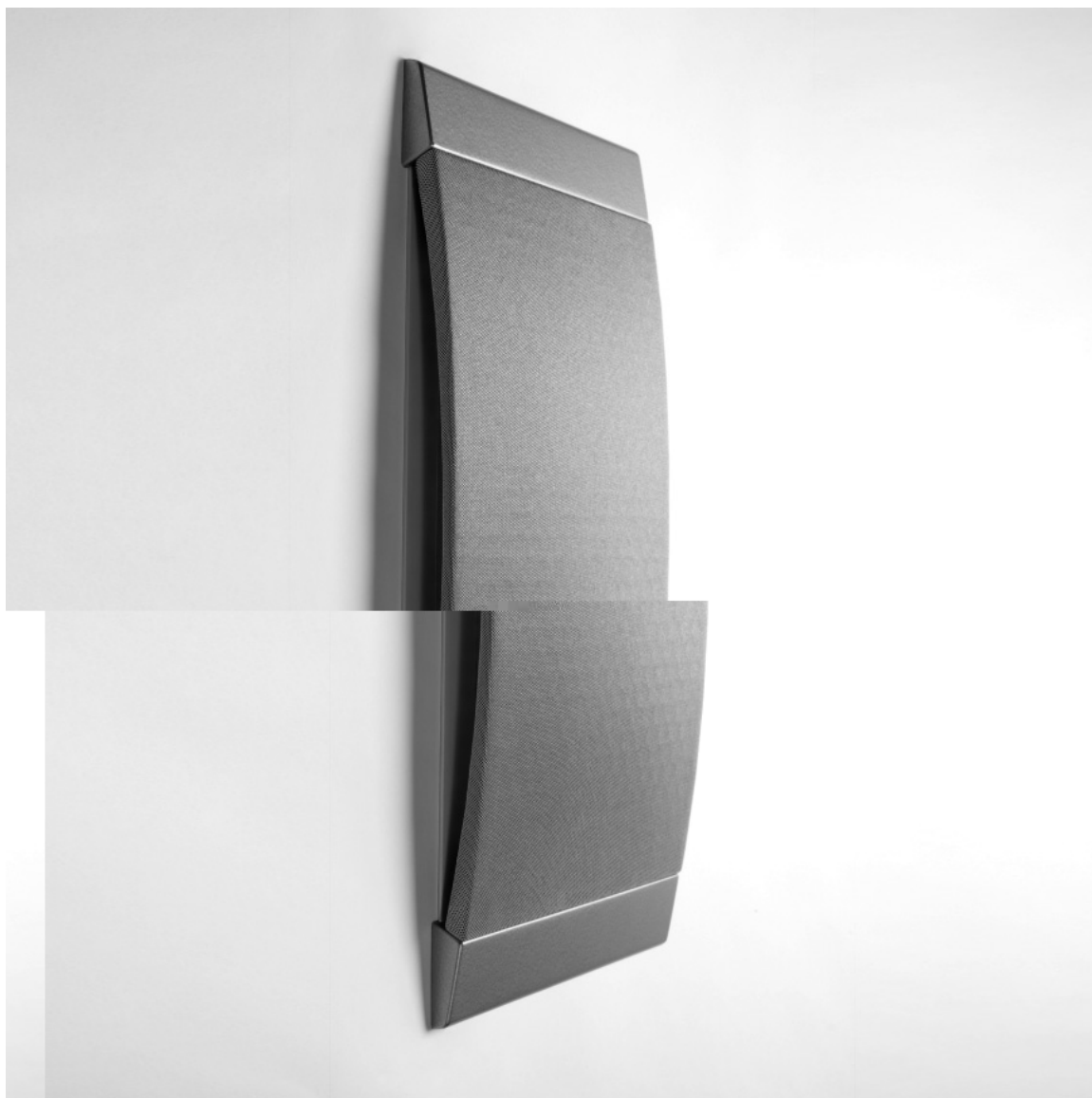

MARTIN LOGAN®
the loudspeaker technology company

CONTENTS AND INTRODUCTION

Contents





Contents and Introduction	2
Contents	
Introduction	
Installation	3
Placement	
Horizontal Installation	
Installing the Ticket	
Removing the End Caps for Painting	8
Frequently Asked Questions and Troubleshooting	9
General Information	10
Specifications	
Warranty and Registration	
Service	
Glossary of Audio Terms	11

Introduction

Congratulations! You have invested in a new world of high performance audio!

The MartinLogan Ticket represents the culmination of an intensive, dedicated group research program directed toward establishing a world class reference monitor utilizing leading-edge technology, without compromising durability, reliability, craftsmanship or aesthetic design. The materials in your new Ticket speaker are of the highest quality and will provide years of enduring enjoyment and deepening respect.

This User's Manual will explain in detail the operation of your Ticket speaker and the philosophy applied to their design. A clear understanding of your speaker will insure that you obtain maximum performance and pleasure from this most exacting transducer. It has been designed and constructed to give you years of trouble-free listening enjoyment.

	The lightning bolt flash with arrowhead symbol within an equilateral triangle is intended to alert the user to the presence of uninsulated "dangerous voltage" within the product's enclosure that may be of sufficient magnitude to constitute a risk of electric shock.
	The exclamation point within an equilateral triangle is intended to alert the user to the presence of important operating and maintenance (servicing) instructions in the literature accompanying the appliance.
	The fire within an equilateral triangle is intended to alert the user to the potential of creating a fire hazard if they do not follow the instructions.
	The dollar sign within an equilateral triangle is intended to alert the user that they run the risk of causing damage that could be potentially expensive to repair if they don't follow the instructions.

	In accordance with the European Union WEEE (Waste Electrical and Electronic Equipment) directive effective August 13, 2005, we would like to notify you that this product may contain regulated materials which upon disposal, according to the WEEE directive, require special reuse and recycling processing.
	For this reason MartinLogan has arranged with our distributors in European Union member nations to collect and recycle this product at no cost to you. To find your local distributor please contact the dealer from whom you purchased this product, email info@martinlogan.com or visit the distributor locator at www.martinlogan.com .
	Please note, only this product itself falls under the WEEE directive. When disposing of packaging and other related shipping materials we encourage you to recycle these items through the normal channels.

	WARNING!
	<ul style="list-style-type: none">• Refer servicing to a qualified technician.• To prevent fire or shock hazard, do not expose this module to moisture.• Turn amplifier off should any abnormal conditions occur.• Do not drive speaker beyond its rated power.



Required tools (included):

- 4mm Allen bit
- (2) Push pins

Required tools (not included):

- Stud finder
- Sharp pencil or pen
- Level
- Dry wall knife/saw
- Wire strippers
- Electric drill (with clutch)
- Tape measure

Depth required behind wall surface:

3 7/16" (9cm)

Required wall opening (includes tolerance):

5 7/8" x 14 1/4" (14.9cm x 36.2cm)

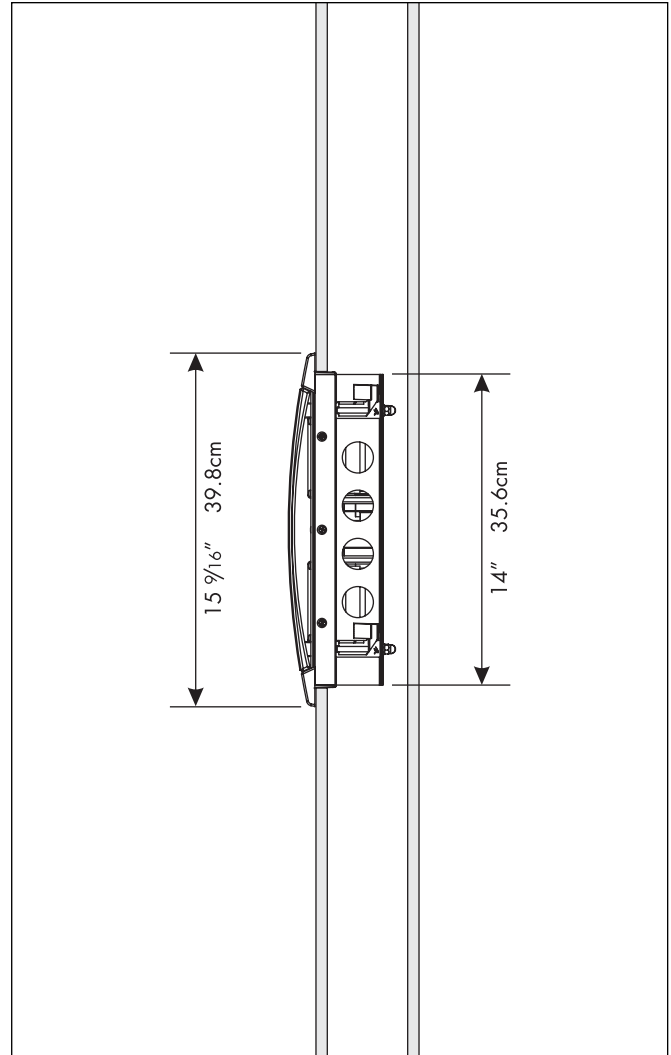

Figure 3. Side view.

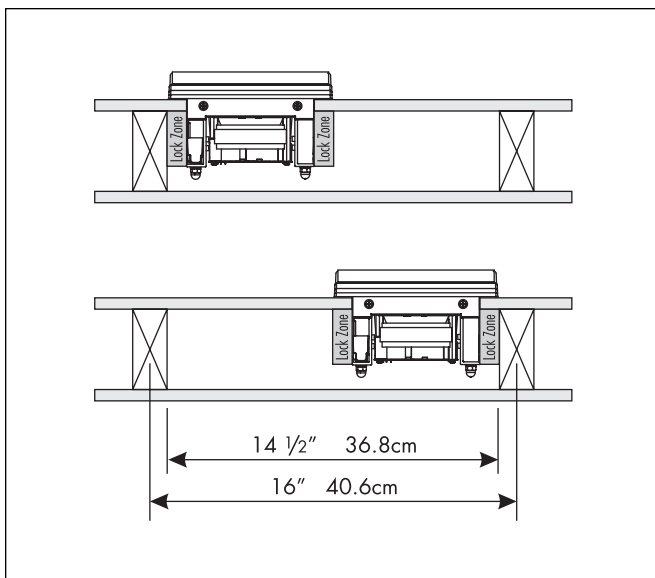

Figure 2. The Ticket is designed to mount anywhere between studs.

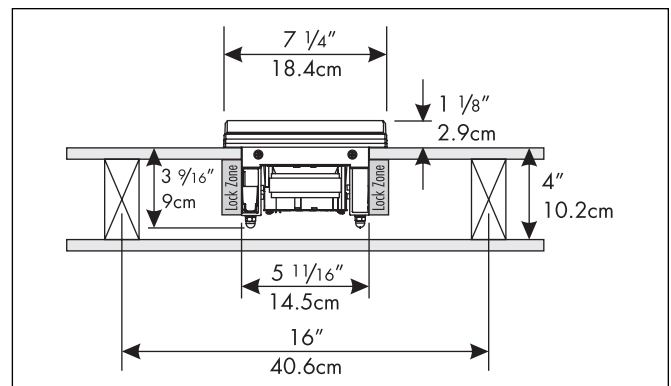

Figure 4. Top view.

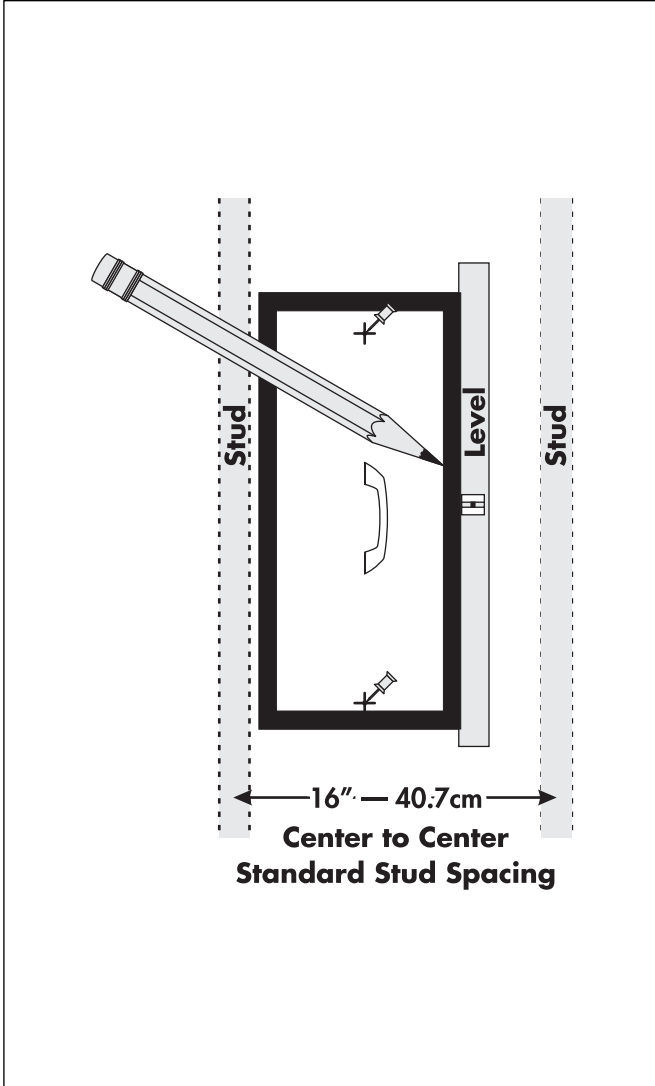

Figure 5. Installation steps 1–3.

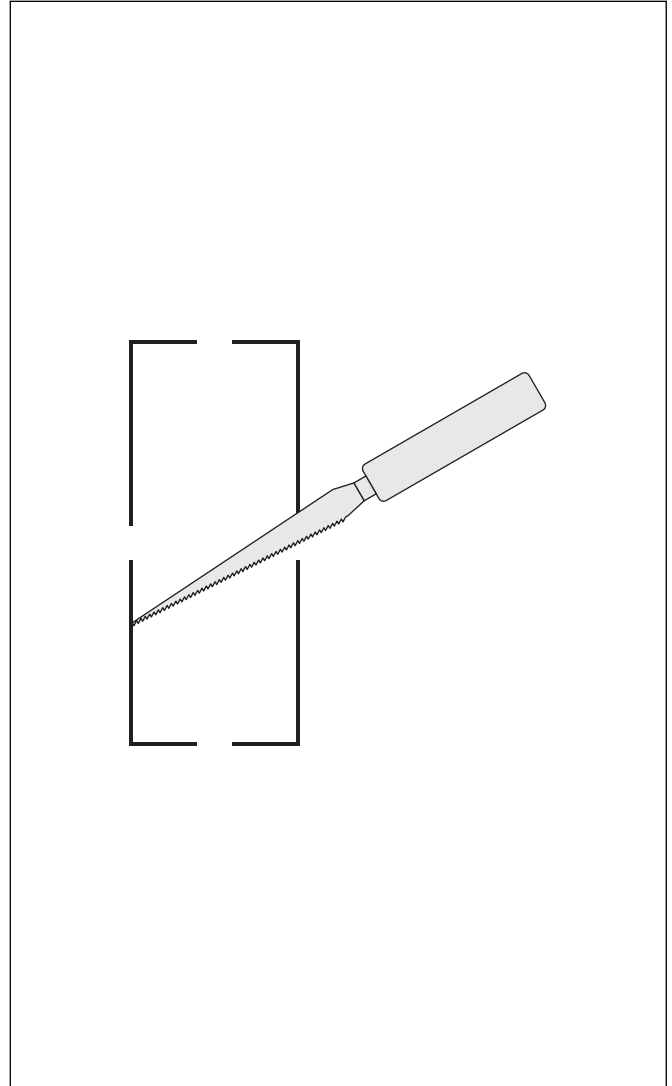

Figure 6. Installation step 4.

- 1 Using a stud finder, locate the final speaker position between studs.



WARNING! Absolutely no part of the template should overlap a stud.

- 2 Insert top push pin (provided). Level template. Insert bottom pushpin (provided). Recheck level.
- 3 Mark cutout through slots in template. Remove Template.

- 4 Use a dry wall knife/saw to cut out the opening.

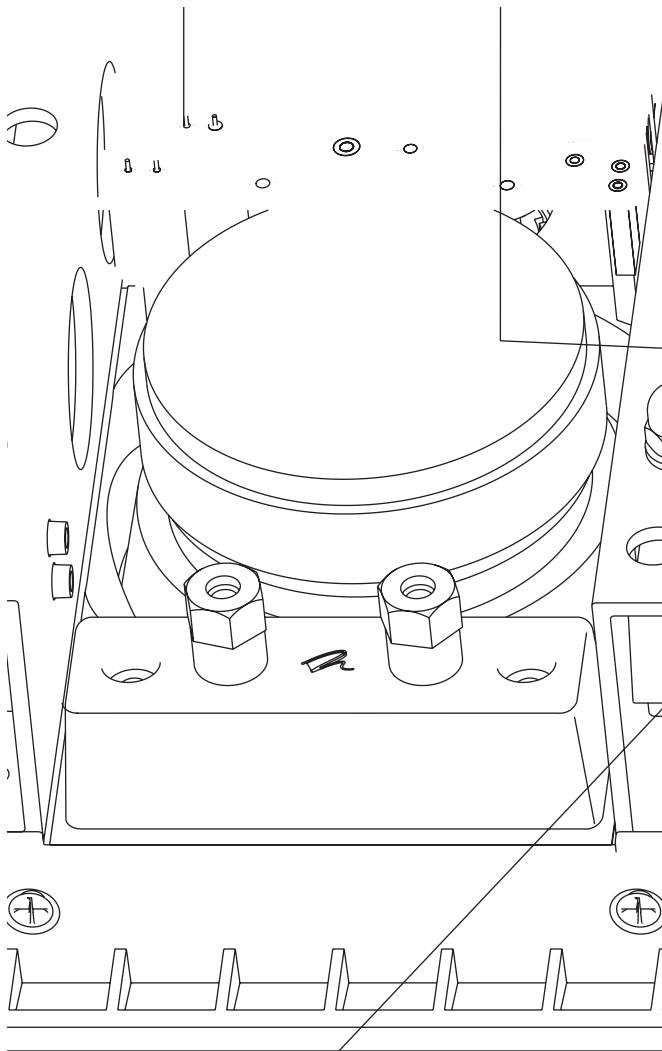

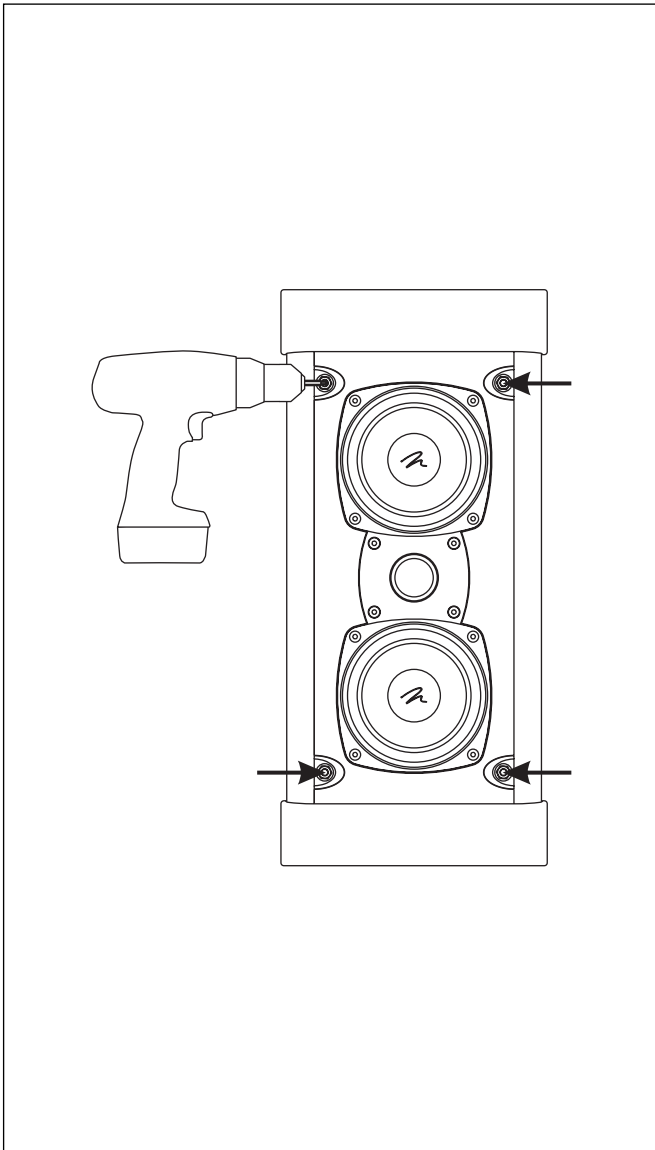

Figure 9. Installation step 7.

- 7 Use a 4mm Allen bit (provided) and an electric drill to lock all 4 mounting locks in place. Use a low clutch setting on the drill.

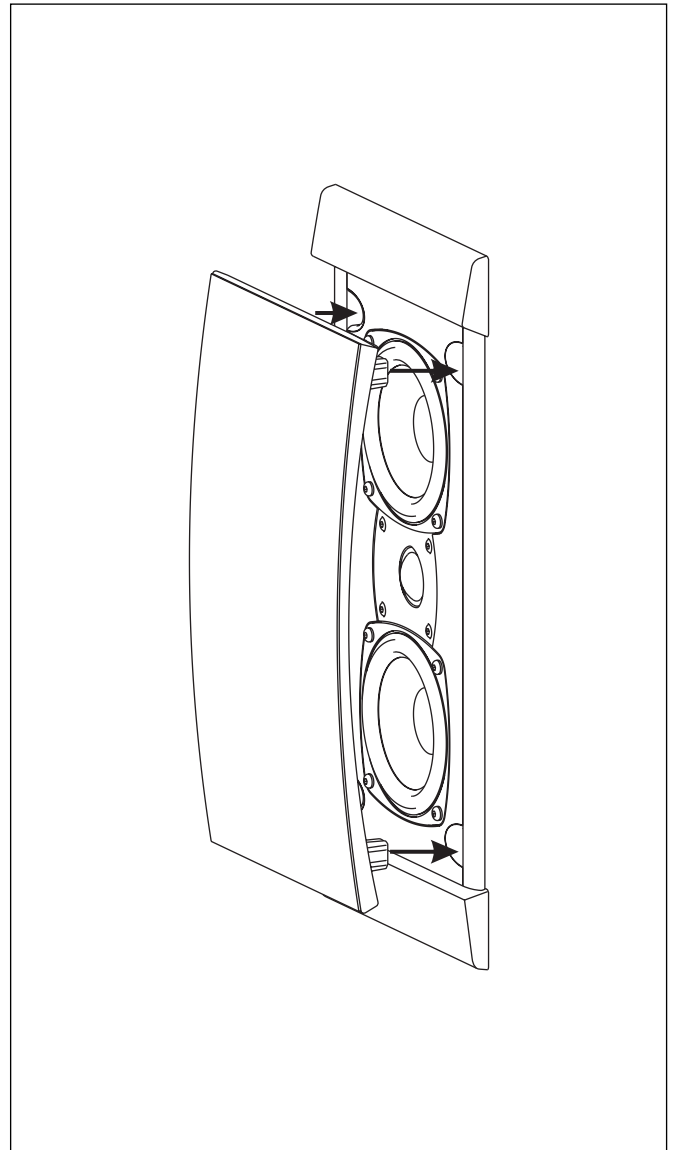
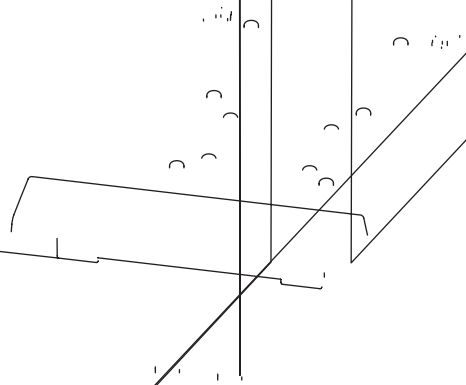

Figure 10. Installation step 8.

- 8 Gently press the grill cover into place.

R



Required tools (not included):

Philips head screwdriver

- 1 Prepare a flat surface with a cushion and/or blanket to protect the Ticket. Place the Ticket driver side up.
- 2 Using a Phillips head screwdriver remove two screws from the bottom edge of the Ticket (see figure 11).
- 3 The end cap may now be safely removed (see figure 12).
NOTE: It is important that the end caps are lifted straight up and away from the speaker body.

Repeat steps 2–3 to remove other end cap.

FREQUENTLY ASKED QUESTIONS AND TROUBLESHOOTING

Frequently Asked Questions

How do I clean my speakers?

Just use a dust free cloth or a soft brush to remove the dust from your speakers. We recommend a specialty cloth (available at the Xtatic shop at www.martinlogan.com) that cleans your speakers better than anything else we have tried. **Do not spray any kind of cleaning agent on or in close proximity to the drivers.**

What size amplifier should I use?

We recommend an amplifier with 100 watts per channel for most applications. Probably less would be adequate when used in home theater where a subwoofer is employed.

Could you suggest a list of suitable electronics and cables that would be ideal for MartinLogan speakers?

The area of electronics and cable choice is probably the most common type of question that we receive. It is also the most subjective. We have repeatedly found that brands that work well in one setup will drive someone else nuts in another. We use many brands with great success. Again, we have no favorites; we use electronics and cables quite interchangeably. We would suggest listening to a number of brands—and above all else—trust your ears. Dealers are always the best source for information when purchasing additional audio equipment or cables and will be well versed in the subject of special safety requirements for in-wall cable.

Will exposure to sunlight affect the life or performance of my speakers?

We recommend that you not place any loudspeaker in direct sunlight. The ultraviolet (UV) rays from the sun can cause deterioration of grill cloth, speaker cones, etc. Small exposures to UV will not cause a problem. In general, the filtering of UV rays through glass will greatly reduce the negative effects.

Troubleshooting

Output

- Check that all your system components are turned on.
- Check your speaker wires and connections.
- Check all interconnecting cables.

GENERAL INFORMATION

Specifications

System Frequency Response

75–20,000 Hz \pm 3 dB

Sensitivity

88 dB/2.83 volts/meter (mounted on wall)

Impedance

8 ohms

Crossover Frequency

2900 Hz

Components

Air core coils

Woofer Type

Two 4" (16.5cm) cast basket, high rigidity aluminum cones with extended throw drive assembly

Power Handling

150 watts

Weight

5 lbs. each (2.3 kg)

Overall Size

7.25" inches W \times 4.69" inches D \times 15.67" inches H
(18.4cm W \times 11.9cm D \times 39.8cm H)

Required wall opening (including tolerance)

5.875" \times 14.25" (14.9cm \times 36.2cm)

Projection from wall surface

1.125" (2.9cm)

Depth required behind wall surface

3.56" (9cm)

Warranty and Registration

Your Ticket speaker is provided with an automatic Limited 90 Day Warranty coverage.

You have the option, at no additional charge, to receive a Limited 5 Year Warranty coverage. To obtain the Limited 5 Year Warranty coverage you need to complete and return the Certificate of Registration, included with your speakers, and provide a copy of your dealer receipt to MartinLogan within 30 days of purchase.

For your convenience MartinLogan also offers online warranty registration at www.martinlogan.com.

MartinLogan may not honor warranty service claims unless we have a completed Warranty Registration on file!

If you did not receive a Certificate of Registration with your new Ticket speaker, you cannot be assured of having received new units. If this is the case, please contact your authorized MartinLogan dealer.

Service

Should you be using your MartinLogan product in a country other than the one in which it was originally purchased, we ask that you note the following:

- 1 The appointed MartinLogan distributor for any given country is responsible for warranty servicing only on units distributed by or through it in that country in accordance with its applicable warranty.
- 2 Should a MartinLogan product require servicing in a country other than the one in which it was originally purchased, the end user may seek to have repairs performed by the nearest MartinLogan distributor, subject to that distributor's local servicing policies, but all cost of repairs (parts, labor, transportation) must be born by the owner of the MartinLogan product.
- 3 If, after owning your speakers for six months, you relocate to a country other than the one in which you purchased your speakers, your warranty may be transferable. Contact MartinLogan for details.

GLOSSARY OF AUDIO TERMS

AC. Abbreviation for alternating current.

Active crossover. Uses active devices (transistors, ICs, tubes) and some form of power supply to operate.

Amplitude. The extreme range of a signal. Usually measured from the average to the extreme.

Arc. The visible sparks generated by an electrical discharge.

ATF. The abbreviation for advanced thin film.

Bass. The lowest frequencies of sound.

Bi-Amplification. Uses an electronic crossover, or line-level passive crossover, and separate power amplifiers for the high and low frequency loudspeaker drivers.

Capacitance. That property of a capacitor which determines how much charge can be stored in it for a given potential difference between its terminals, measured in farads, by the ratio of the charge stored to the potential difference.

Capacitor. A device consisting of two or more conducting plates separated from one another by an insulating material and used for storing an electrical charge. Sometimes called a condenser.

Clipping. Distortion of a signal by its being chopped off. An overload problem caused by pushing an amplifier beyond its capabilities. The flat-topped signal has high levels of harmonic distortion which creates heat in a loudspeaker and is the major cause of loudspeaker component failure.

CLS. The abbreviation for curvilinear linesource.

Crossover. An electrical circuit that divides a full bandwidth signal into the desired frequency bands for the loudspeaker components.

dB (decibel). A numerical expression of the relative loudness of a sound. The difference in decibels between two sounds is ten times the Base 10 logarithm of the ratio of their power levels.

DC. Abbreviation for direct current.

Diffraction. The breaking up of a sound wave caused by some type of mechanical interference such as a cabinet edge, grill frame or other similar object.

Diaphragm. A thin flexible membrane or cone that vibrates in response to electrical signals to produce sound waves.

Distortion. Usually referred to in terms of total harmonic distortion (THD) which is the percentage of unwanted harmonics of the drive signal present with the wanted signal. Generally used to mean any unwanted change introduced by the device under question.

Driver. See transducer.

Dynamic Range. The range between the quietest and the loudest sounds a device can handle (often quoted in dB).

Efficiency. The acoustic power delivered for a given electrical input. Often expressed as decibels/watt/meter (dB/w/m).

ESL. The abbreviation for electrostatic loudspeaker.

Headroom. The difference, in decibels, between the peak and RMS levels in program material.

Hybrid. A product created by the marriage of two different technologies. Meant here as the combination of a dynamic woofer with an electrostatic or ATF transducer.

Hz (Hertz). Unit of frequency equivalent to the number of cycles per second.

Imaging. To make a representation or imitation of the original sonic event.

Impedance. The total opposition offered by an electric circuit to the flow of an alternating current of a single frequency. It is a combination of resistance and reactance and is measured in ohms. Remember that a speaker's impedance changes with frequency, it is not a constant value.

Inductance. The property of an electrical circuit by which a varying current in it produces a varying magnetic field that introduces voltages in the same circuit or in a nearby circuit. It is measured in henrys.

Inductor. A device designed primarily to introduce inductance into an electrical circuit. Sometimes called a choke or coil.

Linearity. The extent to which any signal handling process is accomplished without amplitude distortion.

Midrange. The middle frequencies where the ear is the most sensitive.

NAC. The abbreviation for natural ambience compensation.

Passive crossover. Uses no active components (transistors, ICs, tubes) and needs no power supply (AC, DC, battery) to operate. The crossover in a typical loudspeaker is of the passive variety. Passive crossovers consist of capacitors, inductors and resistors.

Phase. The amount by which one sine wave leads or lags a second wave of the same frequency. The difference is described by the term phase angle. Sine waves in phase reinforce each other; those out of phase cancel.

Pink noise. A random noise used in measurements, as it has the same amount of energy in each octave.

Polarity. The condition of being positive or negative with respect to some reference point or object.

RMS. Abbreviation for root mean square. The effective value of a given waveform is its RMS value. Acoustic power is proportional to the square of the RMS sound pressure.

Resistance. That property of a conductor by which it opposes the flow of electric current, resulting in the generation of heat in the conducting material, usually expressed in ohms.

Resistor. A device used in a circuit to provide resistance.

Resonance. The effect produced when the natural vibration frequency of a body is greatly amplified by reinforcing vibrations at the same or nearly the same frequency from another body.

Sensitivity. The volume of sound delivered for a given electrical input.

Stator. The fixed part forming the reference for the moving diaphragm in a planar speaker.

THD. The abbreviation for total harmonic distortion. (See Distortion)

TIM. The abbreviation for transient intermodulation distortion.

Transducer. Any of various devices that transmit energy from one system to another, sometimes one that converts the energy in form. Loudspeaker transducers convert electrical energy into mechanical motion.

Transient. Applies to that which lasts or stays but a short time. A change from one steady-state condition to another.

Tweeter. A small drive unit designed to reproduce only high frequencies.

Wavelength. The distance measured in the direction of progression of a wave, from any given point characterized by the same phase.

White noise. A random noise used in measurements, as it has the same amount of energy at each frequency.

Woofers. A drive unit operating in the bass frequencies only. Drive units in two-way systems are not true woofers but are more accurately described as being mid/bass drivers.



MARTIN LOGAN[®]
the loudspeaker technology company